

# U-18 MISS VEGAS



**AQUACRAFT**<sup>™</sup>  
Models by **HOBBICO**<sup>®</sup>

## Warranty

**AquaCraft**<sup>™</sup> will warrant this kit for 90 days after the purchase from defects in materials or workmanship. **AquaCraft** will either repair or replace, at no charge, the incorrectly made part.

Make sure you save the receipt or invoice you were given when you bought your model! It is your proof of purchase and we must see it before we can honor the warranty.

To return your U-18 Miss Vegas Hydroplane for repairs covered under warranty you should send your boat to:

**Hobby Services**  
3002 N. Apollo Drive, Suite 1  
Champaign, Illinois 61822  
Attn: Service Department  
Phone: (217) 398-0007, 9:00 am – 5:00 pm Central Time M-F  
E-mail: [hobbyservices@hobbico.com](mailto:hobbyservices@hobbico.com)

## TABLE OF CONTENTS

SPECIFICATIONS & DESCRIPTION CHANGES .....	2
REPAIR SERVICE .....	2
SAFETY PRECAUTIONS .....	2
ITEMS REQUIRED FOR COMPLETION & OTHER	
USEFUL TOOLBOX ITEMS .....	3
OTHER USEFUL ITEMS TO HAVE ON HAND .....	3
BOAT TERMINOLOGY .....	3
FINAL ASSEMBLY .....	3
RUNNING THE ENGINE.....	5
BREAKING IN THE ENGINE .....	6
RUNNING THE U-18 MISS VEGAS HYDROPLANE .....	7
TRIM ADJUSTMENTS FOR THE U-18 MISS	
VEGAS HYDROPLANE .....	8
MAINTENANCE .....	9
RACING .....	10
NATIONAL MODEL BOATING ORGANIZATIONS .....	10
ORDERING REPLACEMENT PARTS .....	11
ENGINE TROUBLESHOOTING FLOWCHART .....	11
AQUACRAFT .18 INBOARD MARINE	
ENGINE EXPLODED VIEW .....	BACK COVER

**Before Building:** Thank you for purchasing the U-18 Miss Vegas Hydroplane! We at AquaCraft know how exciting a new boat purchase can be and we know you're anxious to get started, but please take the time to read these instructions before attempting to operate your model. This manual contains the instructions you need to safely operate and maintain your boat. As with any hobby, there is the possibility of injury. Arming yourself with knowledge is the best way to prevent accidents.

If for any reason you think that this model is not for you, return it to your local dealer immediately. **PLEASE NOTE:** Your hobby dealer cannot accept a return on any model after the final assembly sequence has begun.

## SPECIFICATION & DESCRIPTION CHANGES

All pictures, descriptions, and specifications found in this instruction manual are subject to change without notice. AquaCraft maintains no responsibility for inadvertent errors in this manual.

## REPAIR SERVICE

Repair service is available anytime.

After the 90-day warranty, you can still have your U-18 Miss Vegas Hydroplane repaired for a small charge by the experts at AquaCraft's authorized repair facility, **Hobby Services**, at the address listed on the front page of this manual.

To speed up the repair process, please follow the proceeding instructions.

1. Under all circumstances return the **ENTIRE** system; boat and radio.
2. Make sure the transmitter is turned off, all **batteries are removed and fuel is drained** from the tank.
3. Send written instructions which include: a list of all items returned, a **THOROUGH** explanation of the problem, the service needed and your phone number during the day. If you expect the repair to be covered under warranty, be sure to include a proof-of-purchase date (your store receipt or purchase invoice).
4. Be sure to send your full return address.

## SAFETY PRECAUTIONS

- **Adult supervision** is strongly recommended! **Children should be warned** about the dangers of playing in close proximity to water.
- Use care to **avoid touching the propeller anytime the engine is running**. Pay equally close attention to items such as loose clothing, shirt sleeves, ties, scarves, long hair or loose objects such as screwdrivers or pencils that may fall out of shirt or jacket pockets onto the spinning prop. **If your fingers, hands, etc. come in contact with the spinning propeller, you may be severely injured.**
- Because of the speed and mass of this boat, it is capable of inflicting **property damage** and **severe personal injury** if a collision occurs. **Never run this boat in the presence of swimmers** or where the possibility of collision with people or property exists.
- **Never threaten any wildlife or disturb fisherman with your model boat!** This is the quickest way to get model boating banned from your favorite local pond.
- Radio Control boats are controlled by radio signals, which are subject to possible interference from other R/C transmitters, paging systems or other electrical noise. **Before turning your radio on**, make sure no one else in the area is operating a radio on the same frequency (channel).
- **Model engine fuel is poisonous.** Do not allow it to come into contact with the eyes or mouth. **Always store fuel in a clearly marked container and out of the reach of children.**
- **Model engine fuel is highly flammable.** Keep it away from open flame, excessive heat, sources of sparks, or anything else that might ignite it. **Do not smoke or allow anyone else to smoke** in close proximity to open fuel. Make sure that fuel lines are in good condition so that fuel will not leak onto a hot engine causing a fire.
- **Never operate your engine in an enclosed space.** Model engines, like automobile engines, exhaust deadly carbon monoxide. **Run your engine only in an open area.**

- **Model engines generate considerable heat.** Do not touch any part of your engine until it has cooled. Touching the muffler, cylinder head, or exhaust header may result in a **serious burn**.
- **Use safety glasses when starting or running engines.** The propeller may throw loose material such as sand or gravel into your face.

If the buyer is not prepared to accept the liability associated with the use of this product, the buyer is advised to return this kit immediately in new and unused condition to the place of purchase.

### ITEMS REQUIRED FOR COMPLETION & OTHER USEFUL TOOLBOX ITEMS

The U-18 Miss Vegas Hydroplane can be made ready for the water in just a few minutes. The following items are required to complete assembly:



- HCAP2520 Hot Shot™ 2 Glow starter
- ODOP3130 30% Nitromethane model boat fuel (1 quart)
- DTXP0125 Kwik-Pit™ 250 fuel bottle
- 12 “AA” batteries (FUGP7316 – 16 pk)

It is a good idea to assemble a useful collection of tools and accessories to bring along anytime you head out to the pond. Here are some items you will want to keep handy.

- #2 Phillips screwdriver (HCAR1024)
- Hobbico® heavy-duty diagonal cutter 7" (HCAR0627)
- Metric and standard hex drivers
- Adjustable wrench
- Needle-nose pliers (HCAR0625)
- After Run engine oil (HCAP3000)
- Glow plugs
- Fuel tubing (GPMQ4131)
- Hook & loop material (GPMQ4480)
- Hobby knife (HCAR0109)
- AquaCraft Speed Grease cable lubricant (AQUB9500) or Marine-grade grease (for lubricating the flexible drive cable)
- Zip-ties
- Extra “AA” batteries
- Thread-locking compound
- CA glue and de-bonder

### OTHER USEFUL ITEMS TO HAVE ON HAND

- Paper towels
- Spray-on glass cleaner
- Sunglasses
- Sun block
- Waders or rubber boots
- Cooler with plenty of ice and soda
- Folding table
- Lawn chairs
- First-aid kit
- EZ-up or canopy for shelter

### BOAT TERMINOLOGY

**BOW:** The front of the boat.

**STERN:** The back of the boat.

**PORT:** This is the left side of the boat when aboard and facing the front (bow).

**STARBOARD:** This is the right side of the boat when aboard and facing the front (bow).

**HULL:** The body of the boat.

**DECK:** The top of the boat.

**RUDDER:** The hinged vertical plate mounted at the stern that controls steering.

**SPONSON:** The projections at either side of hull that give lateral stability on the water.

### FINAL ASSEMBLY

Carefully remove your U-18 Miss Vegas Hydroplane from the box and place it atop the pre-built boat stand. Remove all remaining components from the box. **You may wish to keep the box in order to more easily transport and store your U-18 Miss Vegas Hydroplane.**

**Decals have been provided for your U-18 Miss Vegas Hydroplane. Simply cut them out, peel, and stick! See the photos on the box for recommended decal placement.**

#### TRANSMITTER ASSEMBLY

1. Remove the transmitter antenna from the parts bag and screw it into the top of the transmitter. To ensure that the antenna is attached, lightly pull on the base of the antenna. If it slides out, it is not installed properly.

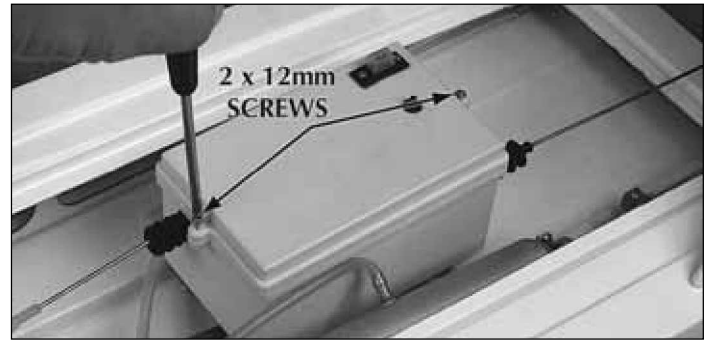
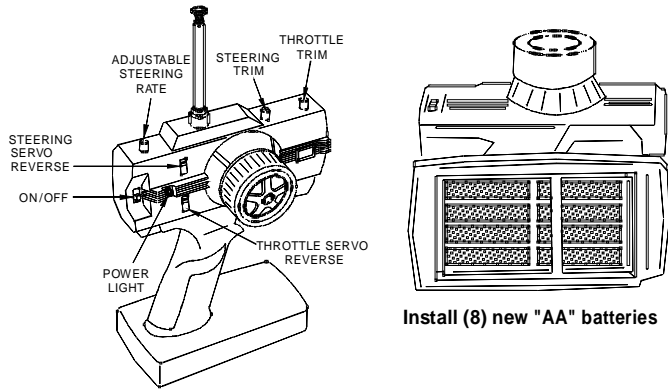

❑ 3. Remove the two (2) 2 x 12mm screws that secure the radio box lid and gently lift the lid from the battery box.

❑ 2. Slide off the battery door on the bottom of the transmitter. Install 8 fresh "AA" batteries into the bottom of the transmitter in the configuration molded into the battery holder. Re-install the battery door onto the bottom of the transmitter.

❑ 3. Turn the transmitter on using the switch on the front. The red LED light next to the on/off switch should light up. If the LED does not light up, turn the transmitter off and check to make sure that the batteries are installed properly. If you see a flashing LED, the batteries are low and need to be replaced.

### INSTALLATION OF RECEIVER BATTERIES

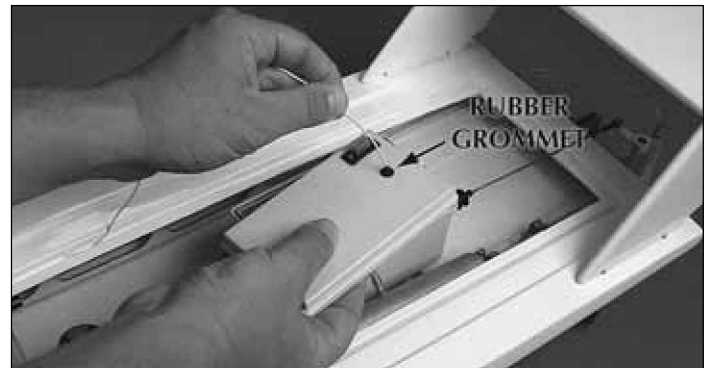

❑ 4. Uncoil the receiver antenna and carefully thread it through the rubber grommet on the radio box lid as shown.

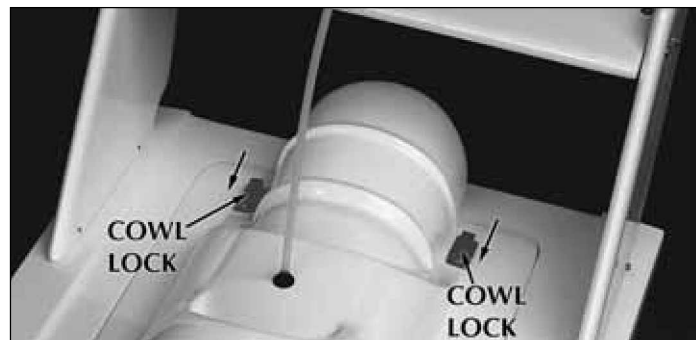

❑ 1. Locate the cowl locks on the rear hatch cover and slide them forward.

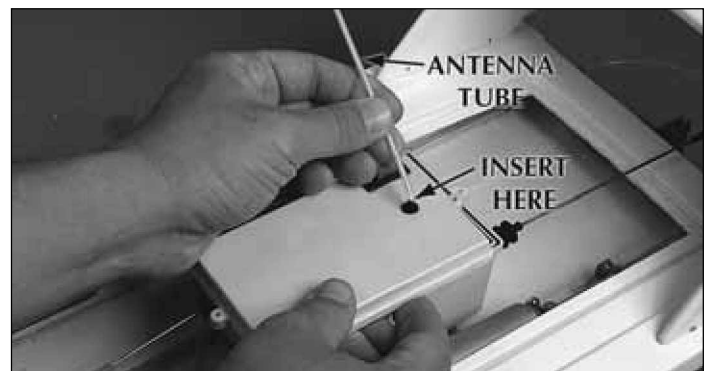

❑ 5. Run the receiver antenna through the antenna tube and insert the tube into the grommet as shown.

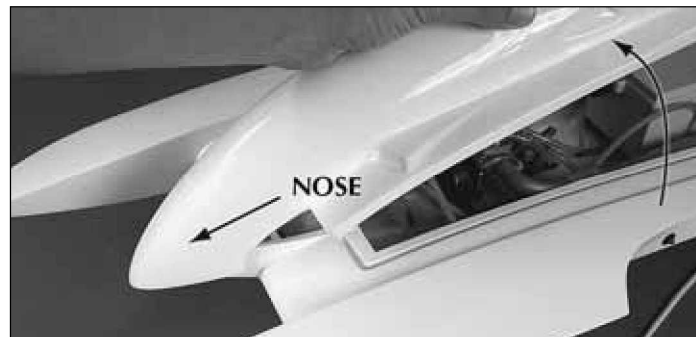

❑ 2. Lift the rear of the canopy and slide it forward to access the interior of the hull.

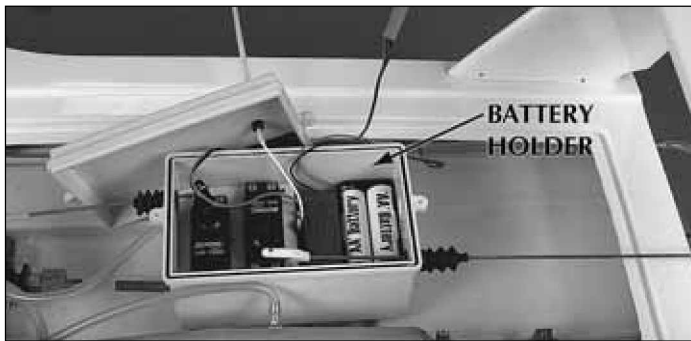

6. Install four fresh “AA” batteries in the battery holder. Be sure to follow the polarity configuration molded into the battery holder.

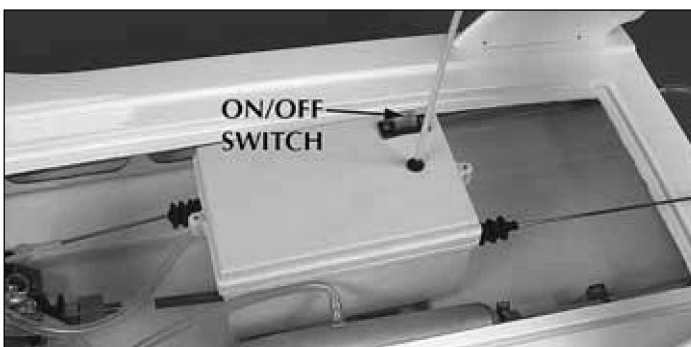
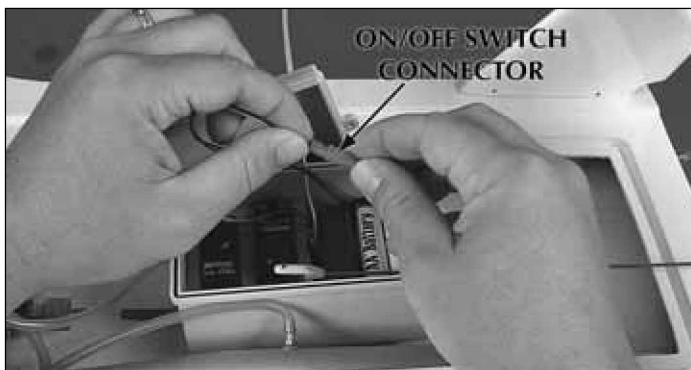

7. Plug the battery box connector into the ON/OFF switch connector. **Do not force them together;** they are designed to fit together only one way.

8. Replace the radio box lid and secure it with the two (2) 2 x 12mm screws.

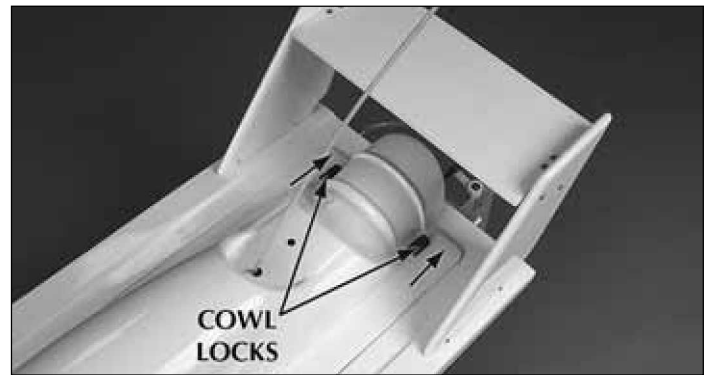

9. Replace the canopy by first sliding it over the “nose” of the boat and then lowering the rear section to meet the hull. Secure it by sliding the two (2) cowl locks toward the rear of the boat.

### CHECK THE RADIO SYSTEM

- Standing behind the boat with both the receiver (vessel) and transmitter powered up, rotate the wheel to the left. The back of the rudder should move towards the left. Move the wheel to the right. The back of the rudder should move towards the right. If this is not the case, simply move the steering servo reverse switch to the other position.
- Squeeze the trigger on the transmitter; this should open the throat of the carburetor. Conversely, moving the trigger forward should close the throat completely.

## RUNNING THE ENGINE

Before running the engine, read the manual completely.

### *There are Several Simple Steps to Starting the Engine:*

1. Install a glow plug if one is not in your engine. The glow plug threads into the top of the cylinder head.
2. Fill the tank almost to the top. Leave a little air at the top of the tank.
3. Open the high-speed needle valve 2-1/2 turns out (**counterclockwise**) from fully closed. The high-speed needle is sticking up on the left side of the carburetor (looking at it from behind the boat). If you have previously run the boat, keep the same needle valve setting that you used on your last run.
4. Prime the engine by placing a finger over the carburetor opening and pulling the starter handle 2-3 times or until you see fuel entering the carburetor. The quantity of fuel drawn into the engine by priming is an important factor in starting the engine successfully.

**IMPORTANT:** The propeller will begin spinning as soon as the engine starts! Be certain that the propeller is unobstructed; failure to do so will damage the prop.

5. Secure the glow starter onto the engine's glow plug.

Carburetor Partially Open

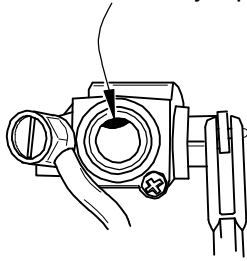

❑ 6. Check that the throttle is 1/8 open from the fully closed position. Pull the handle of the recoil starter in quick, short pulls. Repeat, if necessary until the engine fires. **DO NOT PULL THE RECOIL HANDLE MORE THAN 381mm [15"]**; **DOING SO MAY DAMAGE THE PULL-START.**

❑ 7. With the engine started, remove the glow starter after 10-15 seconds.

❑ 8. Put the cowl back in place and slide the latches toward the rear of the boat to secure it in place. **BE CAREFUL NOT TO TOUCH THE SPINNING PROP!**

If the engine fails to start, refer to the **ENGINE TROUBLESHOOTING FLOWCHART** on page 11.

## FUELS

Use nitro fuels that are specially formulated for model engines. Typically this would be 10-30% nitromethane car or boat fuel.

## BREAKING IN THE ENGINE

To insure long life and good performance from your AquaCraft .18 engine, you **MUST** break-in the engine. The break-in period is critical for long life of the internal parts of the engine. This should be done over the first 5 or 6 tanks of fuel.

### SOME THINGS TO REMEMBER DURING BREAK-IN

- ❑ 1. Use the same fuel that you will use for normal running.
- ❑ 2. Resist the urge to accelerate and decelerate the boat quickly.
- ❑ 3. Break-in puts stress on the glow plug and you can burn it out during break-in. Make sure you have an extra plug or two on hand.

### HOW TO STOP YOUR ENGINE

Just as squeezing the throttle trigger on your transmitter increases power, pushing the trigger the opposite way decreases power. Pushing the throttle trigger forward should close off the throat of the carburetor completely, cutting off air intake and stopping the engine.

## THE FIRST TANK

Your first tank of fuel should be used to run the boat at a very rich high-speed needle valve setting. This allows the fuel to carry as much oil as possible into the engine to lubricate the internal parts during break-in.

- ❑ 1. Open the needle valve 2-1/2 turns out from fully closed (**counterclockwise**). This is factory set already, but check it to make sure. When closing the high-speed needle, close the needle until you feel some resistance. **DO NOT** overtighten or you will damage the carburetor.
- ❑ 2. Start the engine.
- ❑ 3. Once the engine is started, open the high-speed needle valve around 1/8 turn at a time, finding the setting where the engine just barely runs. This may take a few times adjusting the needle. The engine will perform sluggishly and stall from time to time – this is normal during the break-in process.
- ❑ 4. Place the boat in water and run the engine at a medium speed, periodically accelerating and decelerating.
- ❑ 5. Continue running the engine until the tank is almost out of fuel. Do not allow the engine to run out of fuel. This leans out the engine and can cause overheating.

## TANKS 2-6

Turn in the needle valve (clockwise) around 1/8 turn from the previous setting. You should notice that the engine performs better during each run. After the 6<sup>th</sup> tank, you should be near to the peak performance of the engine.

### Ways To Ensure A Long Life For Your Engine.

- Keep your engine clean. Dirt will act as insulation on an engine. It will not be able to shed heat as easily.
- Do not over-lean your engine.
- Do not run your engine without a propeller.
- Do not overheat the engine. This goes along with keeping it clean and not over-leaning the engine.
- Make sure that you use a fuel from a reputable manufacturer that is labeled as model engine fuel.
- Avoid using old fuels in the engine. Always run all of the fuel out of the engine. After running for the day, use after run oil and work it into the engine by pulling the pull-starter 2-3 times.
- Do not use silicone sealer on the engine joints. Silicone sealer contains acetic acid, which is corrosive if it gets inside your engine.
- Store your engine someplace where it will not be subjected to extreme temperature changes.

If you are having problems with your engine, consult the **ENGINE TROUBLESHOOTING FLOWCHART** on page 11 of this manual. The following are some potential problems.

### **GLOW PLUG**

The glow plug is an item that will wear out and need replacement from time to time. It is a good idea to remove the glow plug before your first run, attach it to the glow starter and see how well it glows. You should see a bright orange glow from the filament. If a coil or two will not glow or the plug will not glow at all, replace the plug. If the engine quits when you remove the glow starter, the plug might need to be changed, although this may be because you are running too rich and need to screw in your high-speed needle some. Look at the glow plug when you are running the engine. If you see some bubbles coming from around the plug, replace the glow plug (copper) gasket, or both the plug and the gasket. The only real way to test a glow plug is to replace it. Make sure you have a spare plug or two on hand every time that you run the U-18 Miss Vegas Hydroplane.

### **FUEL**

Fuel can go bad. The main ingredient in model fuel is methanol, which is basically a form of alcohol. Alcohols can absorb water out of the air, so keep your fuel jug capped at all times. Store your fuel out of the sunlight and in a cool place. Bad fuel is one of the most difficult problems to diagnose in engines. If you have tried everything you can think of to remedy an engine that is not running correctly, try using some fresh fuel.

### **FUEL LINE**

Fuel line is susceptible to pinhole leaks. You will not be able to see a hole in the fuel line, but if you see bubbles in the line going to the carburetor, replace the fuel line. Another symptom of a leak in the fuel line is a surging engine. A properly tuned engine will surge when the air bubbles enter the carburetor. It is basically leaning out the mixture.

### **OVERHEATING**

One of the worst things you can do to your engine is overheat it. The oils that lubricate the engine are carried in the fuel. If your engine is set too lean, there will not be enough oil in the engine to lubricate the internal parts. This will cause premature wear in the engine and cause damage.

## **RUNNING THE U-18 MISS VEGAS HYDROPLANE**

**PLEASE TAKE THE TIME TO DO THE FOLLOWING.** Using the provided 10mm and 15mm wrenches, loosen the cable coupler and slide the cable out the back of the boat. Make sure there is adequate grease on the shaft. Reinstall the cable leaving about 3mm [1/8"] between the back of the strut and the front of the drive dog. Tighten the cable coupler making sure it is tight. To check that you have the shaft tight, place a rag over the prop and pull firmly on the shaft/prop.

- Before running your U-18 Miss Vegas Hydroplane, it is also a good idea to check the water-cooling system to make sure all tubes are properly connected.
- Check over all screws to make sure they are securely fastened.
- Total run time of the U-18 Miss Vegas Hydroplane is approximately 6-8 minutes (assuming you begin with a full tank of fuel). When you notice an increase in power, it means the fuel tank is nearly empty and it's time to head for shore. As soon as the boat reaches shore, **stop the engine** by pushing forward on the throttle trigger; turn off the receiver, and finally the transmitter (*in that order*).
- **CAUTION:** The engine will be hot! Allow it to cool for a few minutes before restarting.
- Your U-18 Miss Vegas Hydroplane may occasionally take on small amounts of water, especially when running in rough water. Keep a roll of paper towels handy and dry out the hull interior after every run. If you notice excessive amounts of water in the hull, remove the drain plug in the transom to conveniently drain water from the hull.
- Always store your U-18 Miss Vegas Hydroplane with the canopy/hatch cover removed to allow the interior to dry out completely. If you neglect to do this, it may result in corrosion of the electronic components.
- **IMPORTANT:** If, for whatever reason, your boat takes on a large amount of water, swamps or sinks, causing the radio equipment to get wet, you must do the following immediately: Remove the battery pack and radio equipment from the boat. Allow all of the components to air dry completely before reassembling. Reinstall the components and check for proper operation before running the boat in water.
- Avoid running the boat in cold weather. The hull and other plastic parts can become brittle at low temperatures. In addition, grease and oil become thick, causing premature wear and poor performance.

### **LAUNCH PROCEDURE**

1. Turn the power "ON" to the transmitter and receiver (*in that order*).
2. Start the engine. The propeller will begin spinning as soon as the engine is started. **Be sure to stay clear of the propeller.**
3. Gently place the boat in water that is at least 203mm [8"] deep and free of obstacles (weeds, rocks, sticks, ducks, muskrats, etc.). Be sure to stay clear of the spinning prop during the launch.

**IMPORTANT:** Unlike full-scale boats, model boats race in a clockwise circuit and it is the nature of model race boats to make right turns more easily than left turns. If you absolutely have to turn left, do so at *very slow speed and allow yourself plenty of room*. **Turning left at high speed will flip the boat!**

4. Slowly advance the throttle and note if the boat has a tendency to turn right or left. Adjust the steering trim knob on your transmitter until the boat runs in a straight line when the steering wheel is at neutral.

5. When finished running, stop the engine and turn the power "OFF" to your boat and transmitter (*in that order*).

### TRIM ADJUSTMENTS FOR THE U-18 MISS VEGAS HYDROPLANE

Here are some of the important factors that affect the performance of a hydroplane.

#### PROPELLERS

The FRP (Fiber-Reinforced Plastic) prop that comes with your U-18 Miss Vegas Hydroplane is about the best overall prop for daily running. If your prop has a ding or chip in a blade you need to replace it with a new one before you run the boat again. If you want to step it up and try your hand at even more performance try a metal prop. Octura makes a Y535 beryllium copper that will work very well on your U-18 Miss Vegas Hydroplane. Please heed any warning labels that come with the prop. Take your time sharpening and balancing the prop using a good prop balancer and lots of elbow grease. Please do not run any metal prop without first sharpening and balancing it. Failure to do so will not only slow the boat down but possibly break driveline parts. Also note that the metal props can place more load on your engine and driveline; possibly shortening the life of your hardware.

If you like, Octura offers other props with 3mm [.125"] bore sizing but caution must be taken that you do not use one that is too small or too large for the power of your engine. If these are not available at your local hobby shop, you can contact Octura Models directly at: (847) 674-7351. Stick with a prop that is around 35mm [1-3/8"] in diameter. Also keep a look out for high performance props available soon from AquaCraft/GrimRacer™.

#### PROPELLER DEPTH

Diagram 1

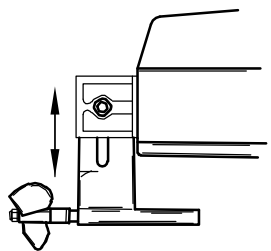

Prop depth adjustment

The depth of the prop is a key factor in establishing the ride attitude of a hydroplane. Lowering the prop depth will raise the back of the boat, resulting in a "bow down" ride attitude. A "bow down" ride increases the amount of sponson wetted surface pinning the boat on the water and reducing top end speed.

Raising the prop depth will lower the back of the boat, creating a "bow up" ride attitude. A "bow up" condition may increase speed but will decrease stability. This may cause the boat to "blow over" (backward flip) or "spin out" in a turn. See Diagram 1.

#### PROPELLER ANGLE

Diagram 2

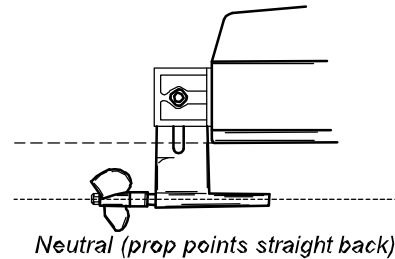
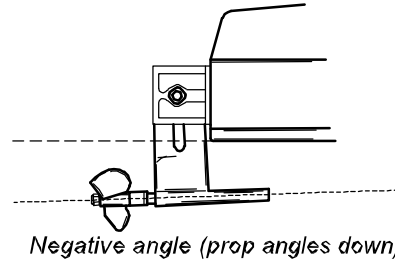
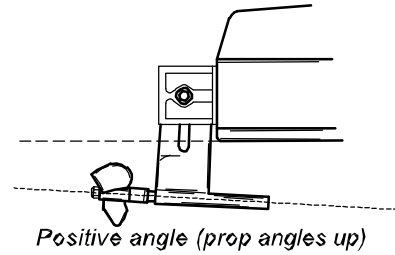

This refers to the angle of the prop shaft in relation to the bottom of the hull. When cutting through the water, the prop produces both thrust and lift. Thrust generates forward movement while lift causes the back of the boat to rise upward. Prop thrust and lift are affected by shape, angle, and size of the prop blades.

Prop angle adjustment is controlled by moving the strut forward or back in the strut mounting bracket. Pushing the strut forward creates "negative" prop angle and will increase the amount of lift because it increases the prop depth. Pulling the strut blade back in the mounting bracket creates "positive" prop angle. This decreases depth and lift. A "neutral" prop angle reduces the effect of prop lift. See Diagram 2.

#### ADJUSTING DEPTH AND ANGLE OF THE PROPELLER

Adjustment of prop depth and angle is accomplished by loosening the 4 x 10mm cap head screw on the strut bracket. Draw a line on the strut blade with a waterproof marker where it meets the strut bracket. This will provide a reference point when making adjustments. It is important to loosen the flexible drive cable from the engine coupler to prevent creating a bind in the driveshaft at the rear of the strut housing.

Like any high performance car, airplane, or boat, optimal outcomes in cornering and speed require "fine tuning" the variables listed above.

The U-18 Miss Vegas Hydroplane is best suited for operation on calm water. Wind creates waves which present challenges to running a hydroplane. An increase in wind will create choppy water conditions, allowing the possibility of "blowing" the boat off when running into the wind.

**With extensive testing, we at AquaCraft have found setting the FRP Y535 prop depth at 27mm [1-1/16"] below the transom provides optimum performance. 27mm [1-1/16"] is to the C/L (centerline) of the prop shaft. Negative 1° to 2° prop thrust is also essential.**

**Performance Tip!** The GrimRacer turn fin (available separately) is designed specifically for .18-size hydros. This fin will help your hydro turn faster with more stability both left, right and in the straights. Blue Finish (AQUB9515), Polished Aluminum Finish (AQUB9516).

## MAINTENANCE

When you are through operating your boat for the day, be sure to perform these basic maintenance procedures. This will prolong the life of the U-18 Miss Vegas Hydroplane and help to ensure trouble-free running.

### ENGINE MAINTENANCE

- Drain any remaining fuel from the tank.
- Remove the glow plug.
- Place a few drops of Hobbico After Run oil (HCAP3000) into the carburetor and in the cylinder head.

### HULL MAINTENANCE

- Remove the hatch cover.
- Open the radio box.
- Soak up any excess water with a paper towel.
- Remove the driveshaft and wipe away as much grease as you can. Spray the driveshaft down with WD-40 and place it in a plastic bag until you are ready to operate the boat again (See the **Driveshaft Maintenance** section below).
- Wipe down the entire boat with spray-on glass cleaner and a paper towel.

### DRIVESHAFT MAINTENANCE

IT IS CRUCIAL that you remove the flexible driveshaft and lubricate it with AquaCraft Speed Grease cable lubricant (AQUB9500) or some type of heavy-duty marine grade cable grease at the beginning of each daily session and again every 2-3 tanks. This exercise will require a 10mm and 15mm wrench.

- ❑ 1. Remove the canopy.

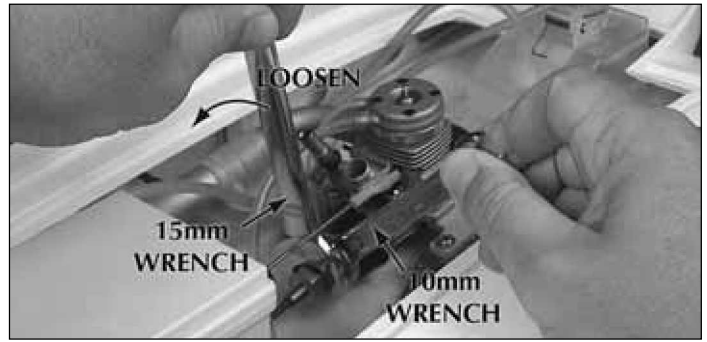

- ❑ 2. Use the 10mm wrench to hold the flywheel nut in place while loosening the collet assembly with the 15mm wrench as shown.

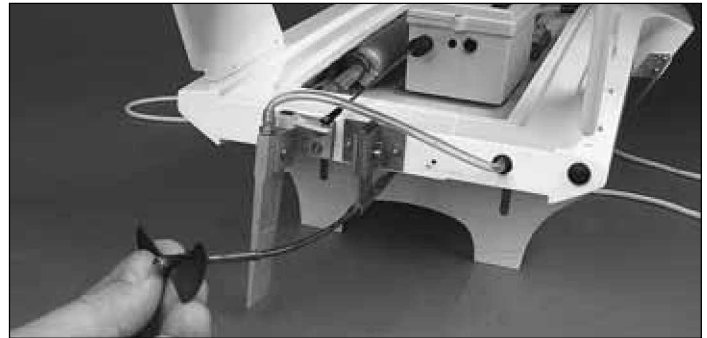

- ❑ 3. Gently pull the driveshaft out and wipe off any old grease.

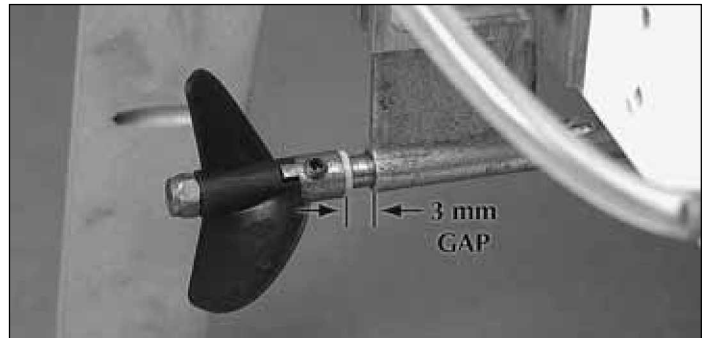

- ❑ 4. Apply AquaCraft Speed Grease cable lubricant (AQUB9500) or heavy-duty marine grade cable grease to the driveshaft and reinsert it into the stuffing box. Slowly rotate the driveshaft while gently pushing it back into place. Be sure to leave about a 3mm [1/8"] gap minimum between the drive dog and the stuffing box as shown.

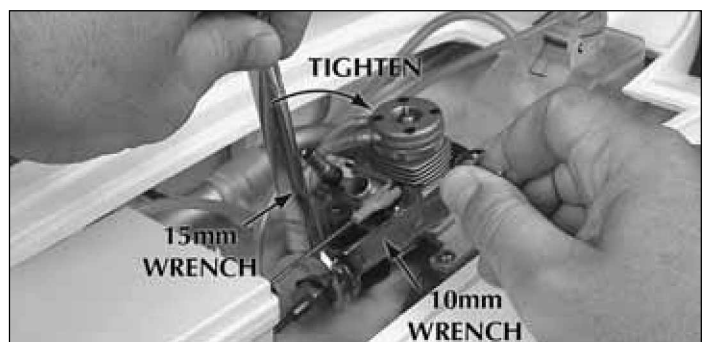

- ❑ 5. Use the 10mm wrench to hold the flywheel steady while tightening the collet assembly with the 15mm wrench as shown. Make sure there is *still* a 3mm [1/8"] gap between the drive dog and the stuffing box.

## RACING

Although it is very enjoyable to go out and run the U-18 Miss Vegas Hydroplane by yourself, the real fun and excitement of R/C boating is experienced when you get involved in racing. Racing against other boats is much different than running your boat alone. The following suggestions will provide helpful strategies when racing a model boat.

A good set-up for running alone may not be the best for racing conditions. Race water conditions create challenges different from running alone. Five or six boats racing against one another will create rough water conditions on the race course and to successfully compete in racing situations, it may be necessary to "tighten" the ride characteristics.

Wakes caused by other boats can upset the balance and ride characteristics of even a well trimmed model boat. When running down the straight-aways, don't follow in another boat's wake. Wakes generated by other boats while entering and negotiating a corner are especially dangerous.

Racing other boats through a corner presents possibly the greatest challenge. The first corner after the start of a race can be especially challenging. The boat entering the corner first has the task of holding its position (often called "holding your lane") through the corner and following boats must then attempt to hold their lanes. Changing lanes and crossing a wake to gain position in a turn can have disastrous results. Executing a good start in the inside lane is one key to successful racing.

Avoid beating yourself. In any type of racing, there are some situations you can control and other situations that you *cannot* control. The ability to set the needle-valve on the engine so it runs the entire race without stopping, checking the linkages, fasteners, fuel tubing, amount of fuel, glow plug, and radio system are conditions/situations that can be dealt with prior to the start of a race. During the race, making a good start and driving defensively are controllable actions. By focusing on tasks and actions that can be controlled, successful racing outcomes can be achieved.

Another good source for information regarding all aspects of model boat operation is:

<http://www.intlwaters.com/>

## NATIONAL MODEL BOATING ORGANIZATIONS

There are three national model boating organizations in the United States and Canada:

**APBA or American Power Boat Association**  
(RC Boat Category)  
[www.apba-rcboating.com](http://www.apba-rcboating.com)

**IMPBA or International Model Power Boat Association**  
[www.impba.net](http://www.impba.net)

**NAMBA or North American Model Boat Association**  
[www.namba.com](http://www.namba.com)

Each of the three organizations has its own rule book governing model boat racing, sanctioned events, and recognized records. Organized model boat racing is offered at both regional and national levels. Location of clubs, race dates and locations, membership applications, and other information can be obtained through their respective websites.

Of course, racing does not *have* to be an organized and sanctioned competition to be fun. Small informal races can be very exciting without the stress that comes with formal events.

Here are some suggestions for setting up a simple racecourse for boats:

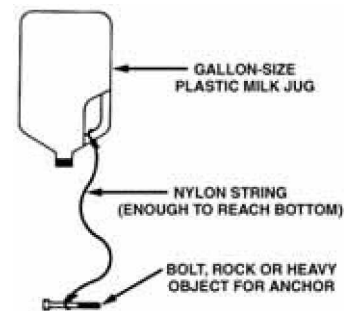

- Make 2 to 4 simple and inexpensive "marker buoys" with empty milk jugs, string, and heavy objects for anchors, similar to the above sketch.

SAMPLE "DRAG RACING" COURSE

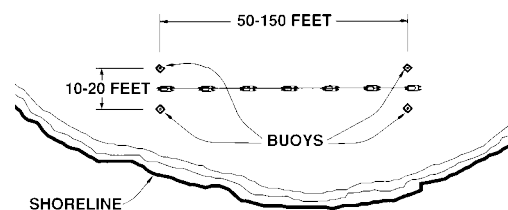

- For "drag racing" place the buoys similar to the above sketch.

SAMPLE "OVAL" RACE COURSE

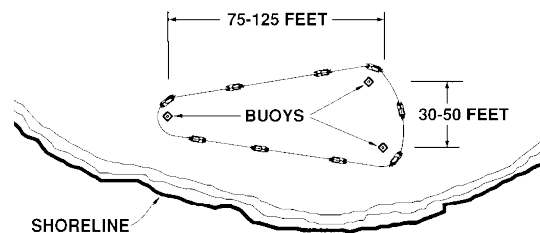

- For "oval racing" place the buoys similar to the above sketch. **Note:** The above patterns are not based on any sort of official standards; therefore, you may set up racecourses any way you choose. Smaller courses provide more action and excitement.

The length of the races can be determined by a set number of laps around the buoys (for example, the first boat to complete